Antenna Qualified to AEC-Q200 6240~8500MHz
Part No: MP11523

Model: DCA60S04
Rev. No: 1

1. FEATURES:

- 1.1. Surface Mounted Devices with a small dimension of 3.2 x 1.6 x 1.1 mm meet future miniaturization trend.
- 1.2 LTCC process
- 1.3 High stability in Temperature / Humidity Change
- 1.4 Multilayer ceramic antenna (chip antenna)

2. APPLICATIONS:

6240~8500 MHz working Frequency

3. CONSTRUCTION:

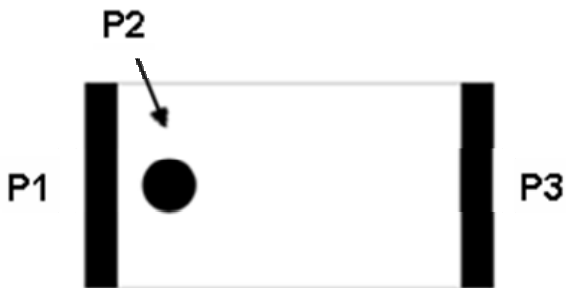

PIN	Connection
1	Feeding
2	Identification Mark
3	Soldering terminal

Antenna Qualified to AEC-Q200 6240~8500MHz
Part No: MP11523

Model: DCA60S04
Rev. No: 1

4. DIMENSIONS:

Figure	Symbol	Dimension (mm)
	L	3.20 ± 0.20
	W	1.60 ± 0.10
	T	1.10 ± 0.10
	A	0.25 ± 0.15

Antenna Qualified to AEC-Q200 6240~8500MHz
Part No: MP11523

Model: DCA60S04
Rev. No: 1

5. ELECTRICAL CHARACTERISTICS:

03A9BD03000051T	Specification
Working Frequency Range	6240~8500MHz
Fc	7370MHz
VSWR	2 max.
Gain	3 to 4.5dBi
Efficiency	70 - 80%
Power Capacity	3W max.
Maximum Input Power	5 Watts for 5 minutes
Polarization	Linear
Azimuth Beamwidth	Omni - Directional
Moisture sensitivity levels	MSL is LEVEL 1 (Refer to : IPC/JEDEC J-STD-020)
HBM ESD	Pass 1KV on all pins (Base on AEC-Q200-002)
MM ESD	Pass 200V (Base on EIA/JESD22-A115)
Operating & Storage Condition (Component) Operation Temperature Range: -55 ~ +125°C Storage Temperature Range: -55 ~ +125°C	
Storage Condition before Soldering (Included packaging material) Storage Temperature Range: +5 ~ +40°C Humidity: 30 to 70% relative humidity	

Antenna Qualified to AEC-Q200 6240~8500MHz
Part No: MP11523

Model: DCA60S04
Rev. No: 1

6. SOLDER LAND PATTERN DESIGN:

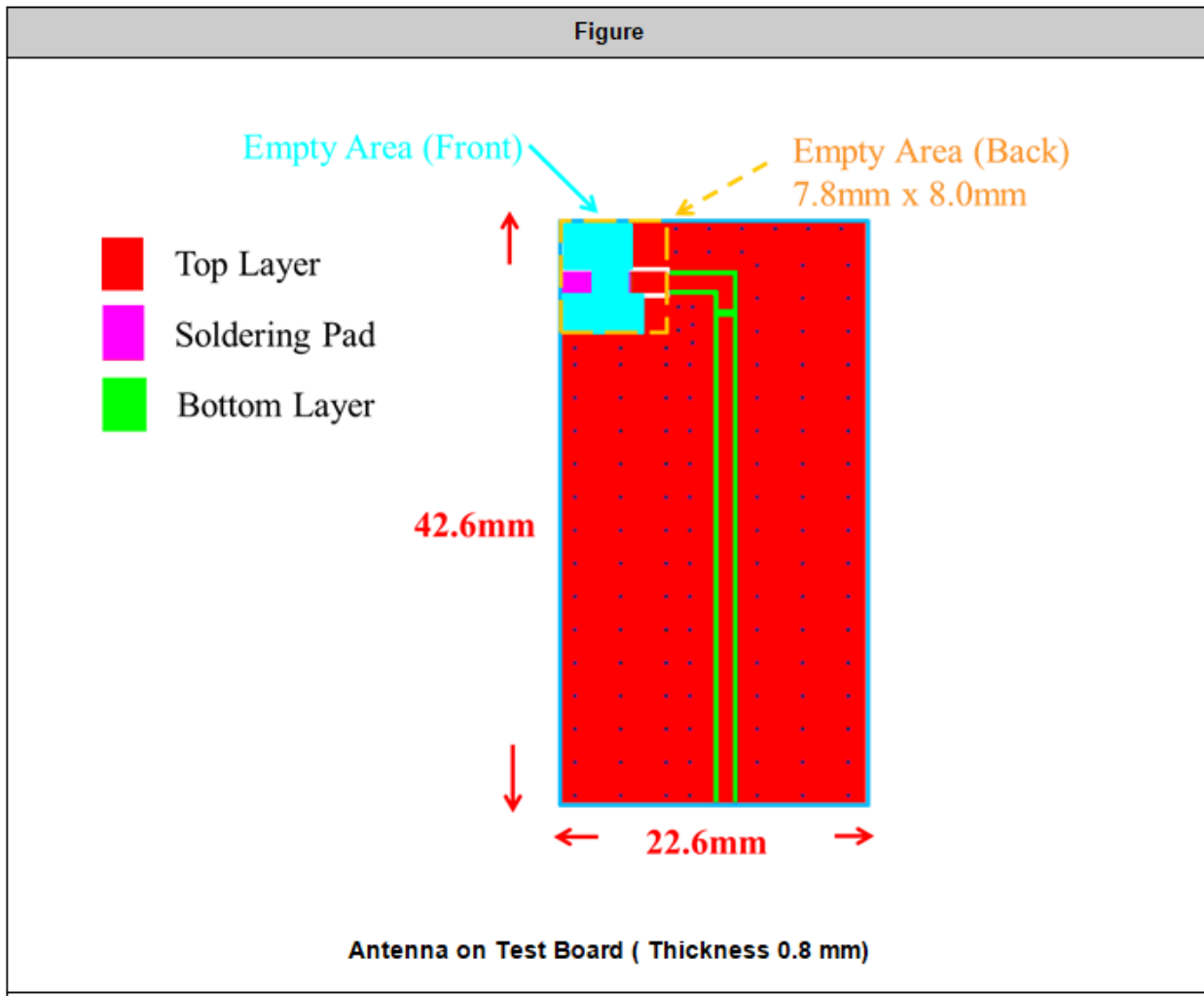

Antenna Qualified to AEC-Q200 6240~8500MHz
Part No: MP11523

Model: DCA60S04
Rev. No: 1

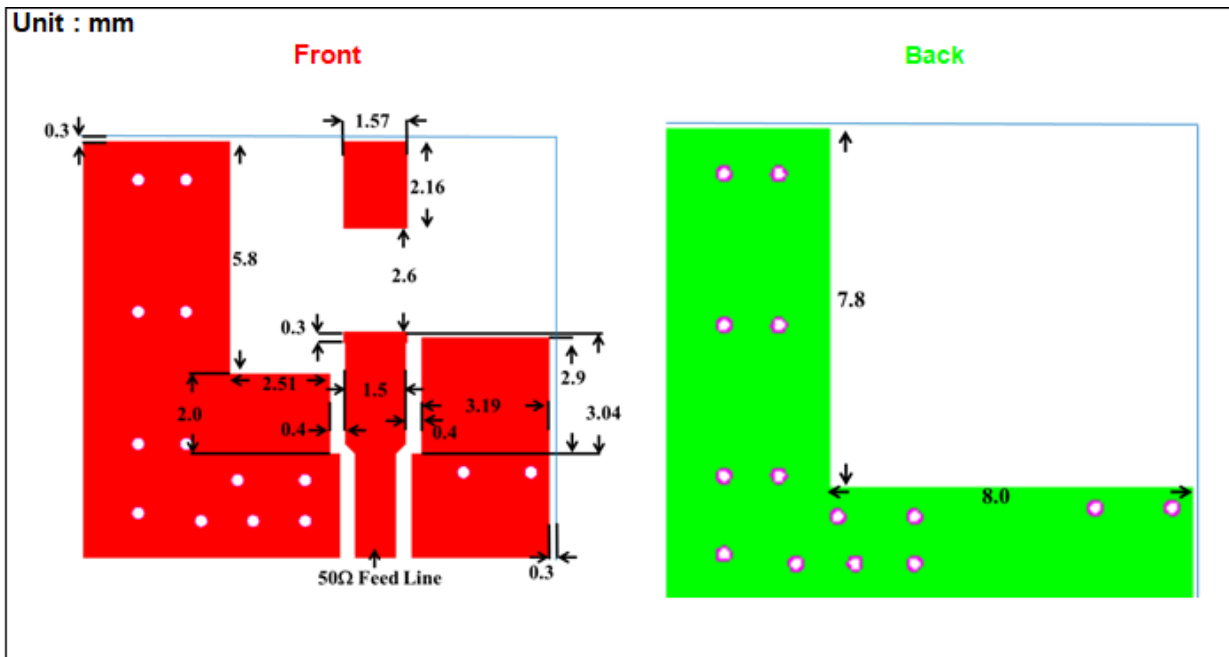

Antenna S11 on Test Board

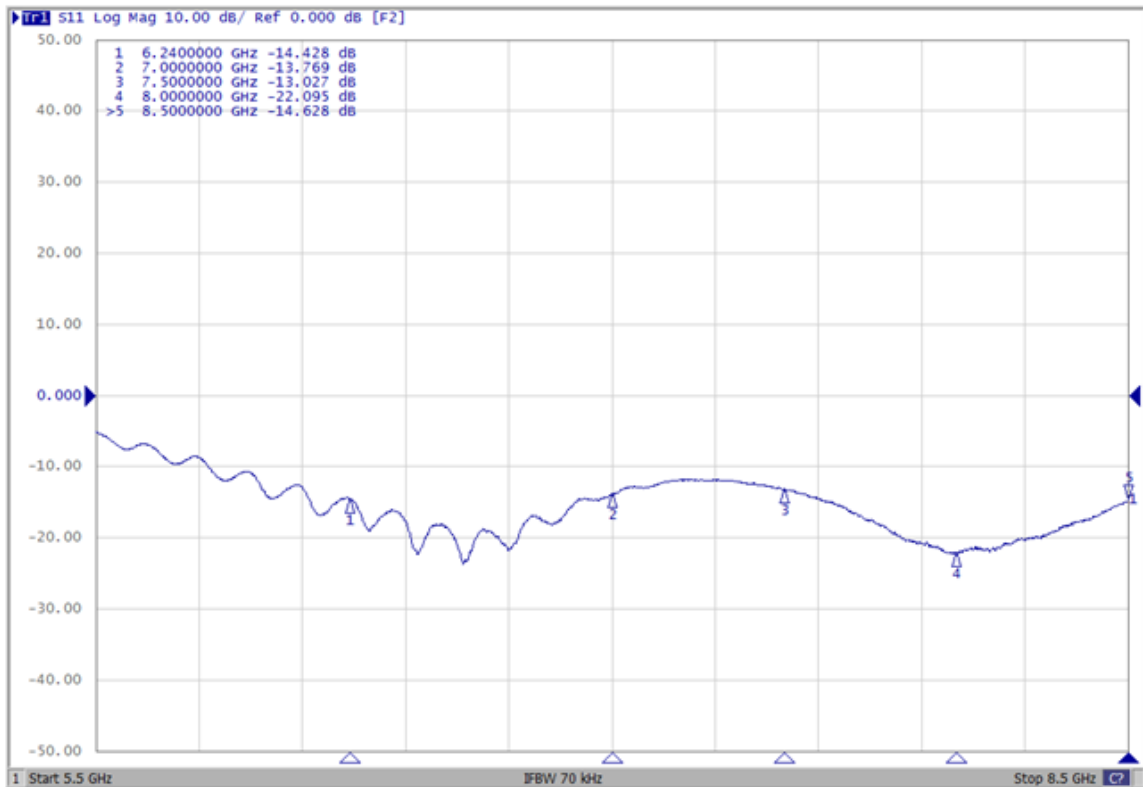

Antenna Qualified to AEC-Q200 6240~8500MHz
Part No: MP11523

Model: DCA60S04
Rev. No: 1

RADIATION PATTERNS

Radiation Pattern and Gain were dependent on measurement board design. The specification of **DCA60S04** antenna was measured based on the PCB size and installation position as shown in the below figure Test Board.

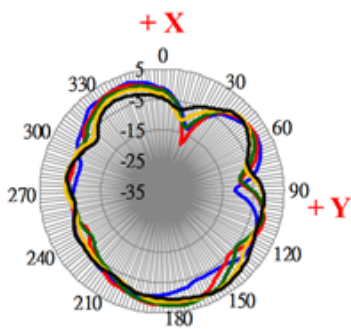
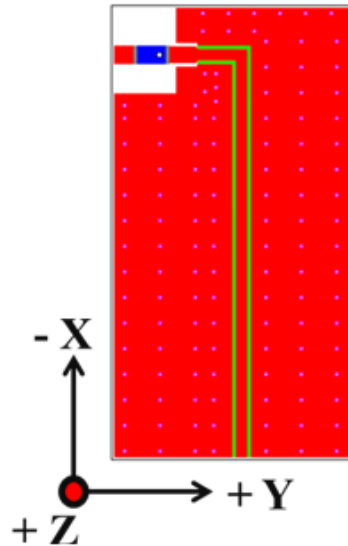

XY Plane

- 6240 MHz
- 7000 MHz
- 7500 MHz
- 8000 MHz
- 8500 MHz

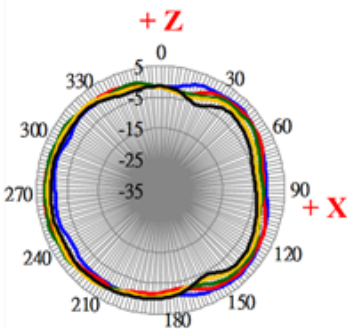

ZX Plane

- 6240 MHz
- 7000 MHz
- 7500 MHz
- 8000 MHz
- 8500 MHz

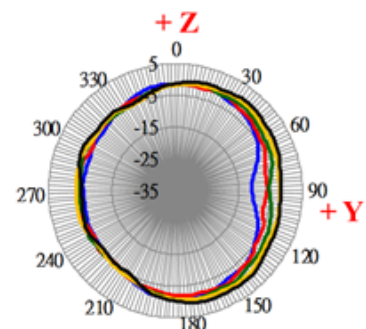

ZY Plane

Antenna Qualified to AEC-Q200 6240~8500MHz

Model: DCA60S04

Part No: MP11523

Rev. No: 1

7. RELIABILITY TEST:

TEST	PROCEDURE / TEST METHOD	REQUIREMENT
Resistance to soldering heat (R.S.H) MIL-STD-202 method 210	Un-mounted chips completely immersed for 10±1second in a SAC solder bath at 270°C ±5°C	No mechanical damage. Electrical specification shall satisfy the descriptions in electrical characteristics under the operational temperature range within -55 ~ 125°C. Loss of metallization on the edges of each electrode shall not exceed 25
Solderability J-STD-002	* Condition A Un-mounted chips 4hrs / 155°C*dry then completely immersed for 5 ±0.5 sec in solder bath at 235 ±5°C. * Condition B Un-mounted chips steam 8 hrs then completely immersed for 10 ±1 sec. in solder bath at 260+0/-5°C.	All terminations shall exhibit a continuous solder coating free from defects from a minimum of 95% of the critical surface area of any individual termination.
Temperature cycling JESD22 method JA-104	1000 cycles, -55°C ~ +125°C, dwell time 30min	No mechanical damage. Electrical specification shall satisfy the descriptions in electrical characteristics under the operational temperature range within -55 ~ 125°C.
Humidity MIL-STD-202 method 103	1000+48/- 0 hours; 85 C, 85% RH	No mechanical damage. Electrical specification shall satisfy the descriptions in electrical characteristics under the operational temperature range within -55 ~ 125°C.
High Temperature Exposure MIL-STD-202 method 108	1000+48/-0 hours; without load in a temperature chamber controlled 125 ±3°C	No mechanical damage. Electrical specification shall satisfy the descriptions in electrical characteristics under the operational temperature range within -55 ~ 125°C.
Mechanical Shock MIL-STD-202 method 213	1/2 Sine Pulse / 100g Peak / Velocity 12.3ft/sec	No mechanical damage. Electrical specification shall satisfy the descriptions in electrical characteristics under the operational temperature range within -55 ~ 125°C.
Board Flex AEC-Q200-005	RF component mounted on a 90mm glass epoxy resin PCB(FR4), bending once 2mm for 60sec	No mechanical damage. Electrical specification shall satisfy the descriptions in electrical characteristics under the operational temperature range within -55 ~ 125°C.
Adhesive Strength of Termination JIS C 0051- 7.4.3	*Pressurizing force : 5N (LGA terminal series) ; 5N(≤0603) ; 10N(>0603) *Test time : 10 ±1 sec	No remarkable damage or removal of the termination.

Antenna Qualified to AEC-Q200 6240~8500MHz
Part No: MP11523

Model: DCA60S04
Rev. No: 1

Vibration MIL-STD-202 method 204	Test 5g's for 20min., 12 cycles each of 3 orientations	No mechanical damage. Electrical specification shall satisfy the descriptions in electrical characteristics under the operational temperature range within -55 ~ 125°C.
ESD AEC-Q200-002	Test contact 1.0KV (0.5KV for 1005 only)	No mechanical damage. Electrical specification shall satisfy the descriptions in electrical characteristics under the operational temperature range within -55 ~ 125°C.

8. SOLDERING CONDITION:

Typical examples of soldering processes that provide reliable joints without any damage are given in Fig 2 This product could sustain by reflow process three times, and the temperature below 260°C.

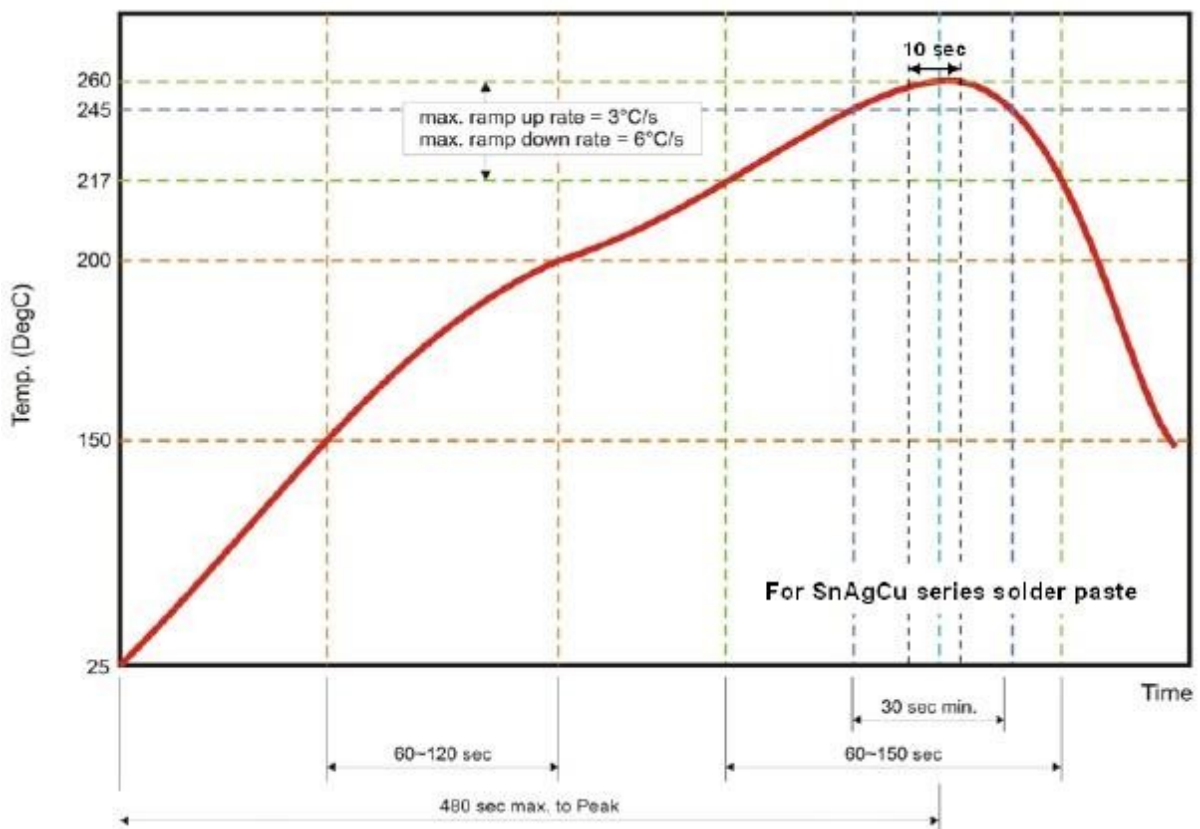

Antenna Qualified to AEC-Q200 6240~8500MHz
Part No: MP11523

Model: DCA60S04
Rev. No: 1

9. PACKAGING:

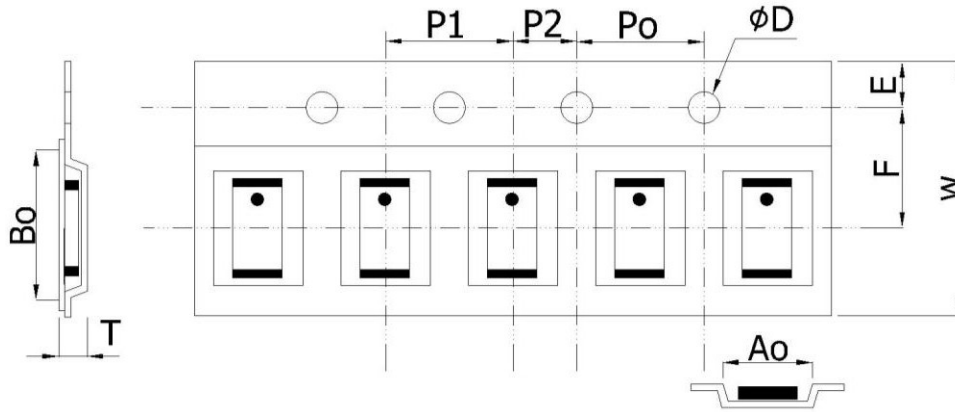

Plastic Tape specifications (unit:mm)

Index	A_0	B_0	ϕD	T	W
Dimension (mm)	1.81 ± 0.10	3.42 ± 0.10	1.55 ± 0.05	1.26 ± 0.10	$8.20 +0.10$ -0.30
Index	E	F	P_0	P_1	P_2
Dimension (mm)	1.75 ± 0.10	3.50 ± 0.05	4.00 ± 0.10	4.00 ± 0.10	2.00 ± 0.10

10. REEL DIMENSIONS:

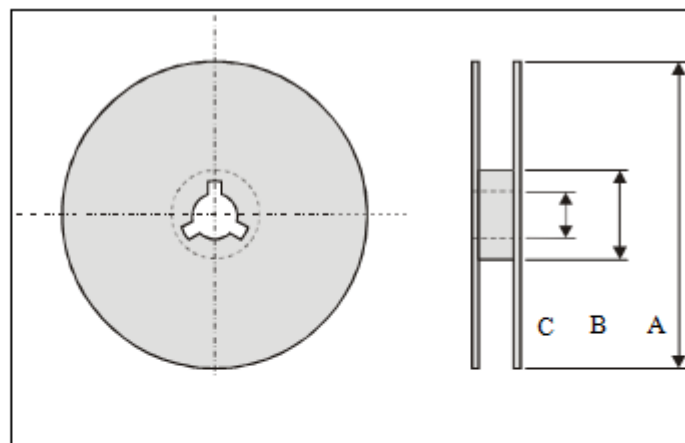

Index	A	B	C
Dimension (mm)	$\phi 178$	$\phi 60.0$	$\phi 13.5$

Typing Quantity: 2000 pieces per 7" reel

Antenna Qualified to AEC-Q200 6240~8500MHz
Part No: MP11523

Model: DCA60S04
Rev. No: 1

11. CAUTION OF HANDLING:

Limitation of Applications

Please contact us before using our products for the applications listed below which require especially high reliability for the prevention of defects, which might directly cause damage to the third party's life, body or property.

- Aircraft equipment
- Aerospace equipment
- Undersea equipment
- Medical equipment
- Disaster prevention / crime prevention equipment
- Traffic signal equipment
- Transportation equipment (vehicles, trains, ships, etc.)
- Applications of similar complexity and /or reliability requirements to the applications listed in the above.

Storage condition

Products should be used in 6 months from the day of outgoing inspection.

Storage environment condition.

Products should be storage in the warehouse on the following condition s.

- Temperature: +5 to +40°C
- Humidity: 30 to 70% relative humidity
- Don't keep products in corrosive gases such as sulfur. Chlorine gas or acid or it may cause oxidization of electrode, resulting in poor solderability.
- Products should be storage on the palette for the prevention of the influence from humidity, dust and son on.
- Products should be storage in the warehouse without heat shock, vibration, direct sunlight and so on.
- Products should be storage under the airtight packaged condition.